

PASSENGER'S SIDE COMPARTMENTS CONTAIN THE FOLLOWING:

- COMPARTMENT P1 CONTAINS:
 - (1) INVERTED ADJUSTABLE SHELF
 -
 -
- COMPARTMENT P2 CONTAINS:
 - (1) SWING OUT TOOLBOARD
 - (1) RACK FOR LITTLE GIANT LADDER
 - (1) RACK FOR 3 PIKE POLES
 - (1) 2-WAY FLOOR MTD SLIDE OUT TRAY
 -
- COMPARTMENT P3 CONTAINS:
 - (1) FLOOR MOUNTED TRAY
 - (1) 42" DP ADJ SLIDE OUT TRAY
 - (1) AKRON ELECTRIC REEL WITH 200' OF 10/3 YELLOW CORD
 -
- COMPARTMENT P4 CONTAINS:
 - (1) CAB LIFT CONTROLLER
 - (1) VERTICAL REAR WALL DIVIDER
 - (1) RACK FOR 2 BACKBOARDS
 - (1) SPECIAL ADJUSTABLE SHELF
 - (1) 1/2 DEPTH ADJ SHELF
 - (1) AKRON ELECTRIC REEL WITH 200' OF 10/3 YELLOW CORD
 -

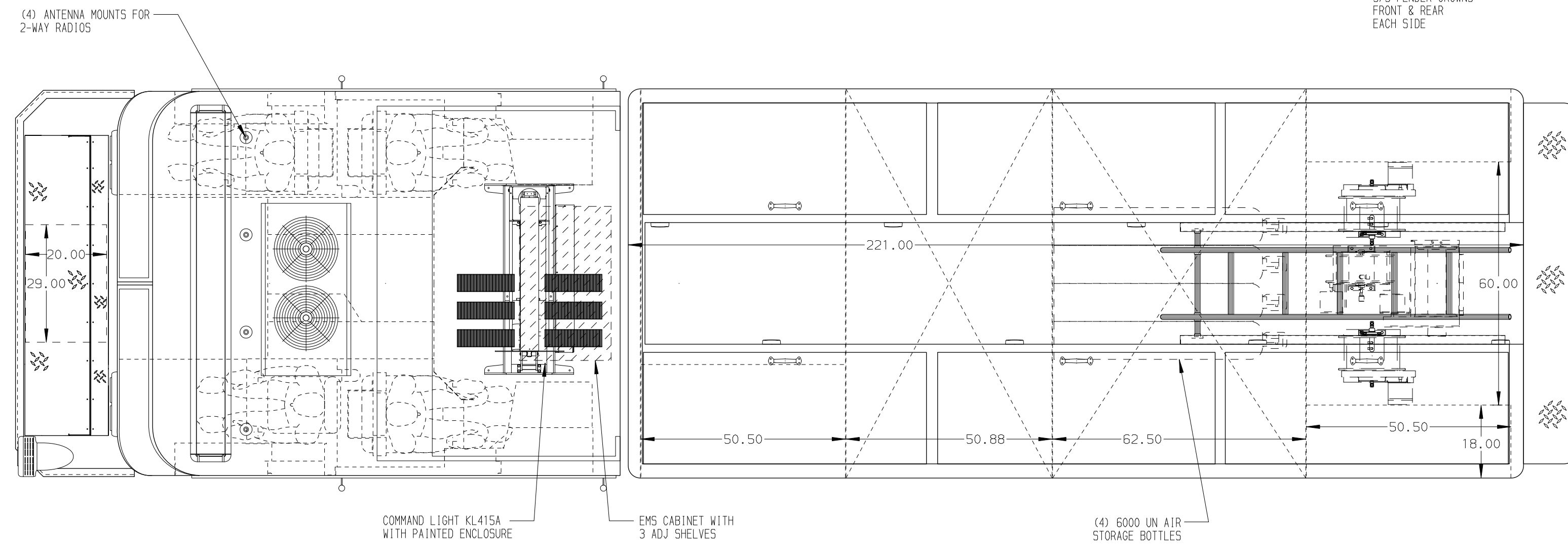
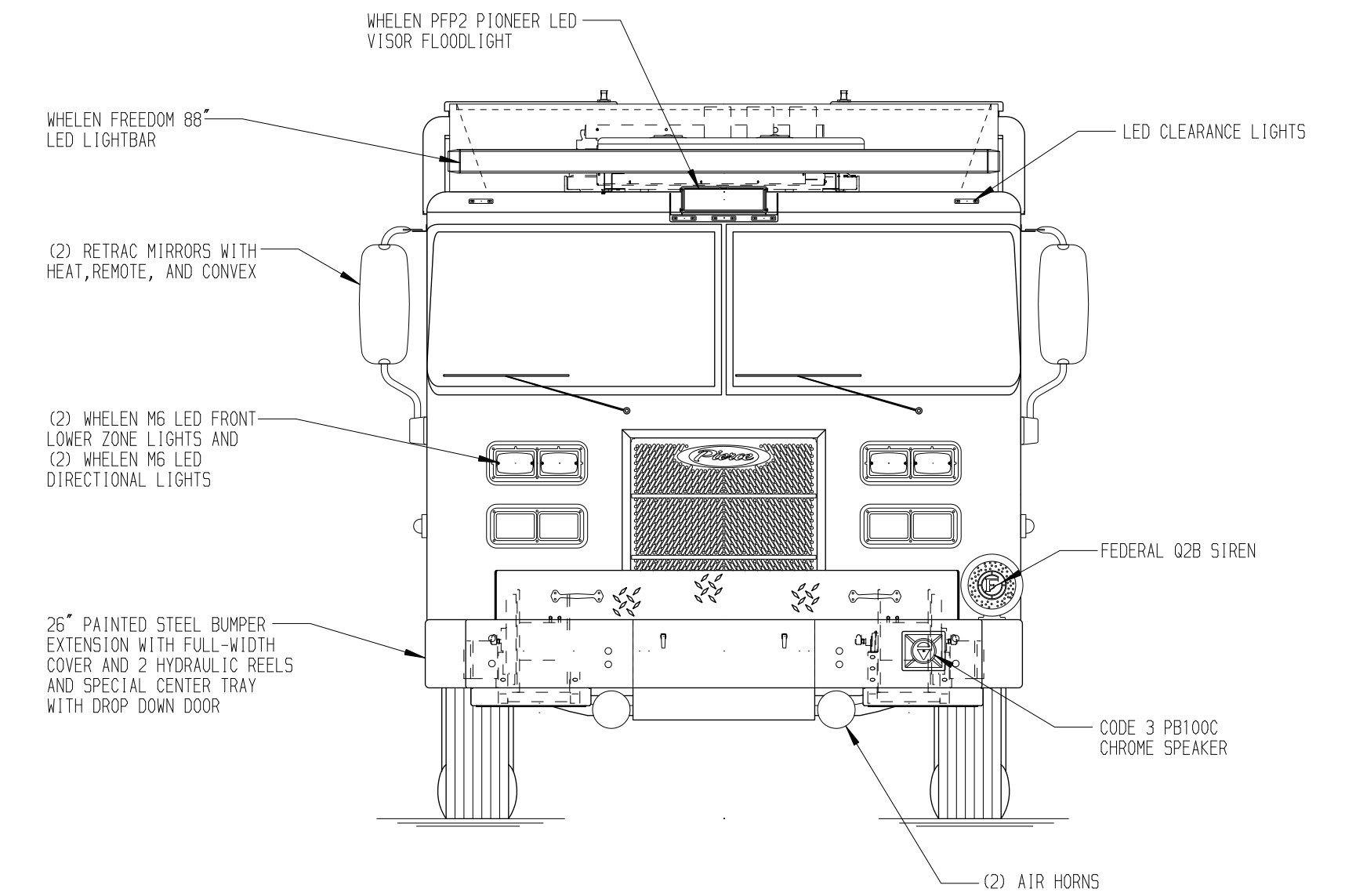
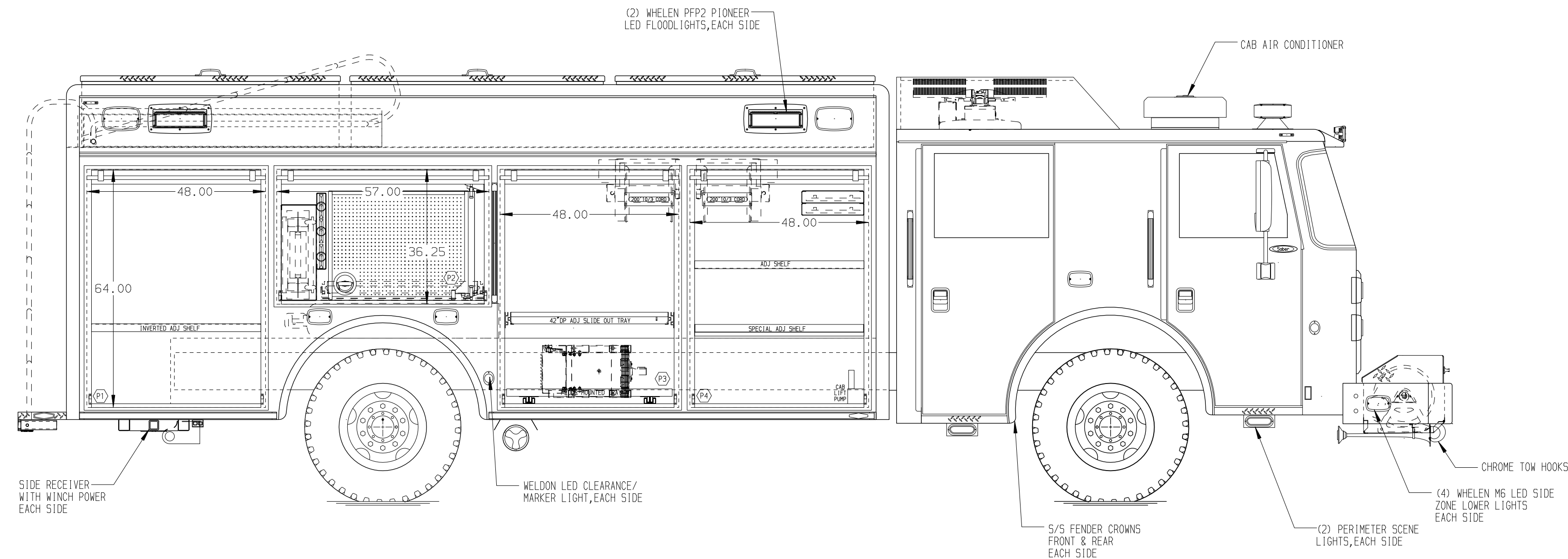

REAR COMPARTMENT CONTAINS THE FOLLOWING:

COMPARTMENT R1 CONTAINS:
 - (1) FLOOR MOUNTED TRAY
 - (1) AKRON ELECTRIC REEL WITH 100' OF 10/3 BLACK CORD
 - (1) 48" DP ADJ SLIDE OUT TRAY
 - (1) LOW PRESSURE AIR REEL W/150' OF HOSE
 - MOUNTING PROVISIONS FOR 2 HYDRAULIC REELS
 - (1) 30A, 240V T.L. RECEPTACLE
 - (1) SPECIAL GUSSETED SHELF
 - (1) CIRCUIT BREAKER PANEL

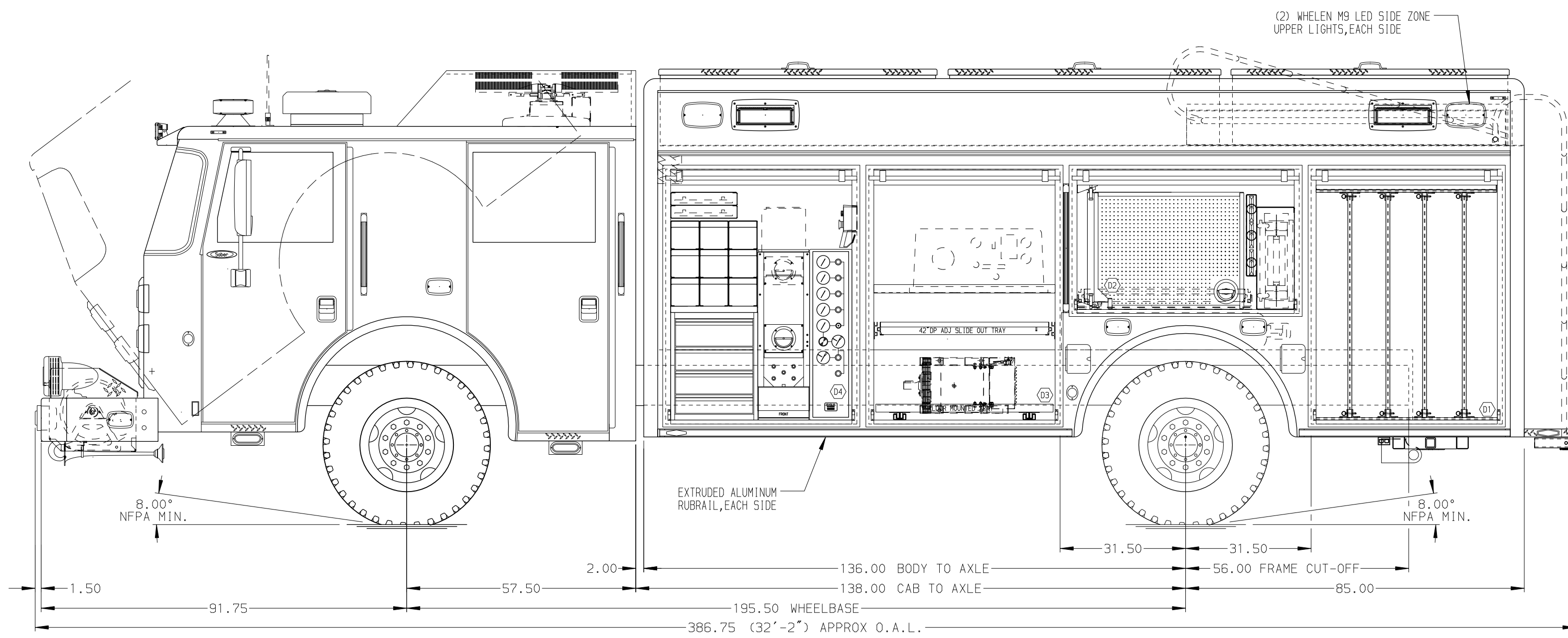

DRIVER'S SIDE COMPARTMENTS CONTAIN THE FOLLOWING:

COMPARTMENT D1 CONTAINS:
 - (4) ADJUSTABLE TOOLBOARDS
 -

COMPARTMENT D2 CONTAINS:
 - (1) SWING OUT TOOLBOARD
 - (1) RACK FOR LITTLE GIANT LADDER
 - (1) RACK FOR 3 PIKE POLES
 - (1) 2-WAY FLOOR MTD SLIDE OUT TRAY
 -

COMPARTMENT D3 CONTAINS:
 - (1) FLOOR MOUNTED TRAY
 - (1) 42" DP ADJ SLIDE OUT TRAY
 - MOUNTING BRACKET FOR SIERRA BOOSTER PUMP
 -

COMPARTMENT D4 CONTAINS:
 - (1) NEWMAR PT-40 CHARGER
 - (1) 4-DRAWER TOOL CABINET
 - (1) "SPACE SAVER" 2-BOTTLE FILL ENCLOSURE
 - (1) CASCADE SYSTEM CONTROL PANEL
 - (1) RACK FOR 9 SCBA BOTTLES
 - (7" SQUARE OPENINGS)
 - (1) VERTICAL REAR WALL DIVIDER
 - (1) LIGHT TOWER CONTROLLER
 - (1) RACK FOR 2 BACKBOARDS

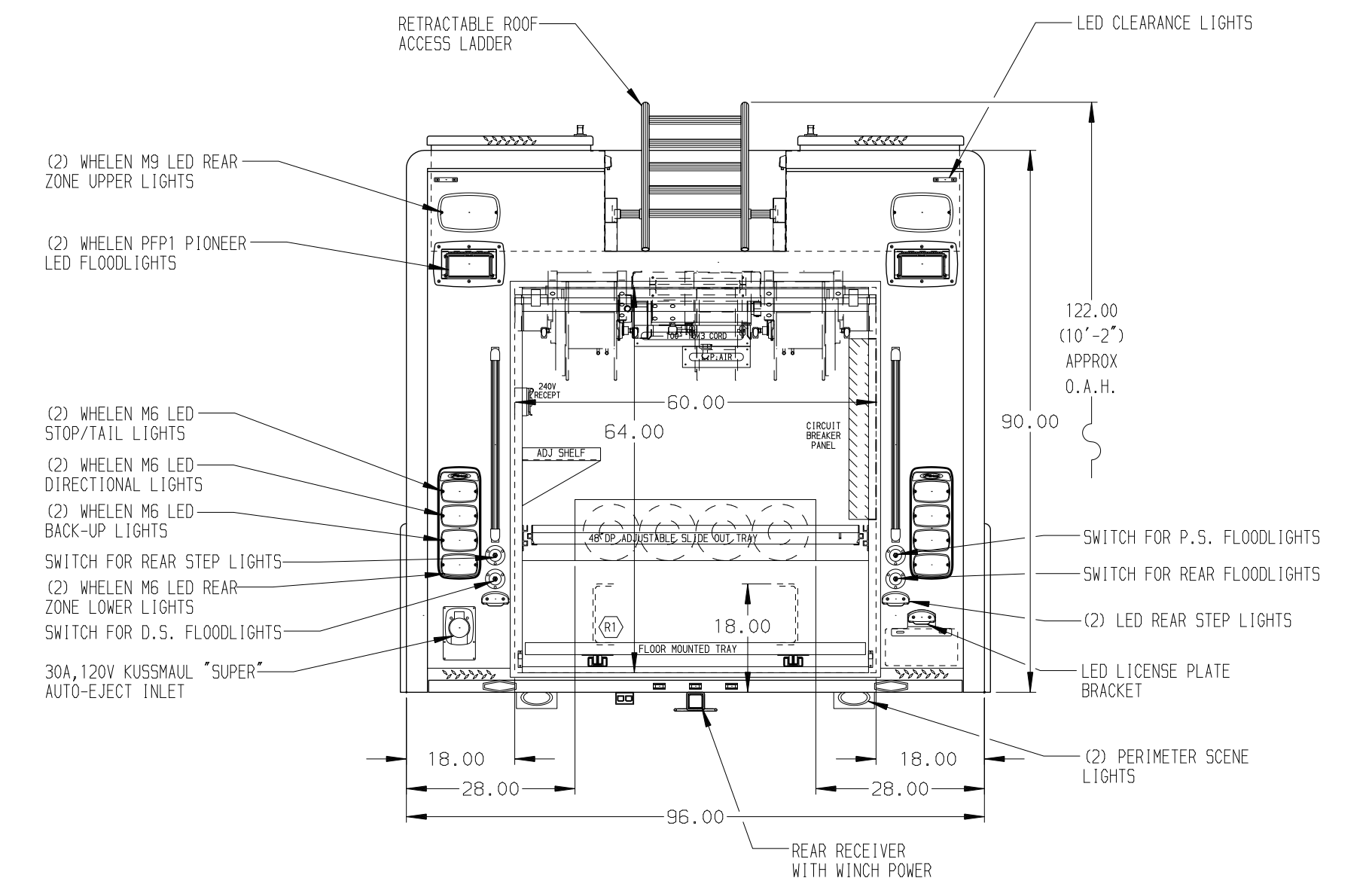

NOTE
 DIMENSIONS SHOWN ARE APPROXIMATE AND ARE SUBJECT TO MINOR DEVIATIONS AS MAY OCCUR OR BE NECESSARY IN CONSTRUCTION. MINOR DETAILS NOT SHOWN.

- NOTES:**
- AIR INLET WITH DISCONNECT COUPLING LOCATED IN THE DRIVER'S SIDE CAB STEP AREA
 - WARN 9,000# WARN PORTABLE WINCH
 - FLOOR IN CAB AND CREW CAB TO PADDED RUBBER
 - BATTERY CHARGE INDICATOR LOCATED ON DRIVER'S SEAT RISER
 - PIERCE DUAL LED STRIP LIGHTS IN ALL BODY COMPARTMENTS
 - ONAN 25kW SINGLE PHASE PTO DRIVEN GENERATOR LOCATED BETWEEN THE FRAME RAILS

CUSTOMER APPROVAL

APPROVED BY: _____
 DATE: _____



JOB NO. 28218

SCALE 1:24 DATE

DRAWN BY DHE 150CT14

CHECKED BY AZU 160CT14

SHEET SIZE SHEET NO.

D 1 OF 1

REV	DATE	BY	CH	SABER	TITLE	FOR	DWG NO.
					CHASSIS DATA	HEAVY DUTY RESCUE NON-WALKIN	
					MAKE	LARGO FIRE RESCUE LARGO, FL	
					MODEL		

28218AD