



## AUTOREACH® SIDE LOADER



**One of the strongest side loaders around, and the only side loader that can reach side to side.**

- The only side loader that can articulate from side to side. The 8-foot arc allows for extreme agility around obstacles and tight spots.
- Arm rated to lift 2,000 pounds, one of the strongest among side loaders in the industry.
- Tandem pump allows for operation of all functions when at idle speeds, keeping noise and fuel consumption low.
- Grabber assembly can grasp cans from 30 to 110 gallons easily; optional extended fingers can handle cans up to 300 gallons.
- Maximizes efficiency and capacity, featuring a large hopper with 4.7 usable cubic yards.
- Excalibre™ cylinders designed exclusively for the AutoReach are specifically equipped to handle high cycle counts, as well as help manage cylinder life and total cost of ownership.

### PERFORMANCE SPECIFICATIONS (in seconds)\*

#### WORKING RPM @ IDLE

Arm In	2.5
Arm Out	2.5
Arm Up	2.5
Arm Down	2.5
Grabber Open	1
Grabber Close	1
Packer Extend	12
Packer Retract	7
Pack Assist Up	2
Pack Assist Down	2
Tailgate Open	15
Tailgate Close	19
Body Up	14
Body Down	26

Compaction = up to 900 lb/yd

\*Cycle times may vary slightly

### ARM SPECIFICATIONS

Arm Style	Side mounted, articulating
Arm Lifting Capacity	2,000 lb
Arm Reach	8 ft, with side-to-side articulation

### HOPPER SPECIFICATIONS

Hopper Capacity	4.7 cu yd
Lower Hopper Sides	Left: 3/16 in. AR200 Right: 10-gauge ASTM A607 grade 50
Upper Hopper Sides	10-gauge ASTM A1011/A1018 grade 50 high-strength steel
Hopper Floor Wear Area	3/16 in. AR450
Hopper Assist Panel	12-gauge ASTM A1011/A1018 Grade 50

### OPERATIONS

McNeilus multiplexed and distributed CAN-based controls, with air joystick, offer proven reliability and functionality

### PACKER/EJECTOR SPECIFICATIONS

Packing Face	1/4 in. AR200
Follower Panels	10-gauge ASTM A1011/A1018 Grade 50
Track & Wear Strips	Chromium carbide X-wear

### BODY SPECIFICATIONS

Body Floor	10-gauge AR200
Side Walls	1/8 in. AR450/AR200
Roof	12-gauge ASTM A1011/A1018 Grade 50

### TAILGATE SPECIFICATIONS

Tailgate Rear & Side Walls	1/8 in. AR450
Seven-Point Automatic Locking Tailgate	

### HYDRAULICS

Pump	Dual Vane or Gear with Pack-on-the-Go flow control system
Oil Reservoir	50 gallon
Return Filter	Schroeder K9
Suction Strainer	40 mesh stainless steel

### CYLINDERS

Packer Cylinder	4-1/2 in. bore x 3 in. rod x 52-3/4 in. stroke
Tailgate Cylinder	2-1/2 in. bore x 1-1/2 in. rod x 38 in. stroke
Grabber Cylinder	2 in. bore x 1 in. rod x 6-1/4 in. stroke
Reach	3-1/2 in. bore x 2 in. rod x 14-3/4 in. stroke
Lift	3-1/2 in. bore x 2 in. rod x 17-8/9 in. stroke
Swing	2 in. bore x 1-1/4 in. rod x 9-3/25 in. stroke

### PAINTING

Packer and components steel shot blasted, then primed and painted separately to provide complete top coat coverage to all areas  
Finish : PPG high-performance, high solids acrylic urethane topcoat

### McNEILUS WARRANTIES

Contact your McNeilus representative on warranty details.  
For more information, go to [www.McNeilusGarbageTrucks.com](http://www.McNeilusGarbageTrucks.com)

# AUTOREACH® AUTOMATED SIDE LOADER

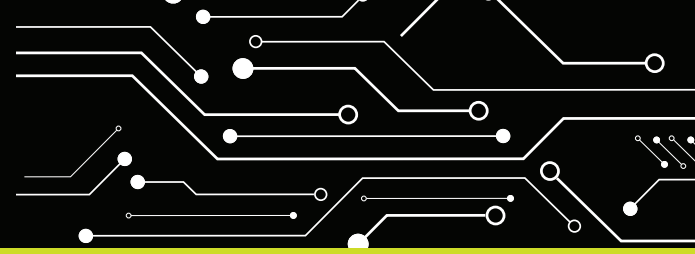

- McNeilus CNG Systems and Service offers compressed natural gas systems in a variety of configurations and capacities for the AutoReach.
- High-quality, abrasion-resistant steel in all high-wear areas for outstanding strength and durability.
- McNeilus partners with top equipment dealers across North America to provide best-in-class support and access to service and parts close to home.
- Proudly made in the USA.

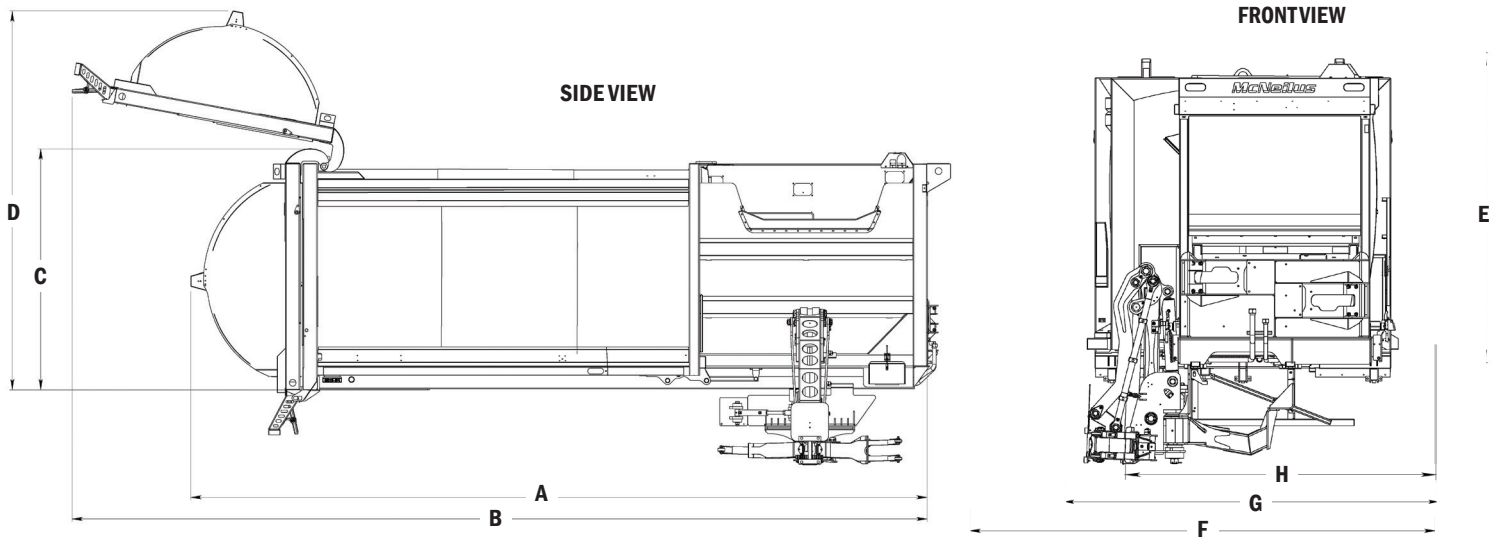

## DIMENSIONS

DESCRIPTION	22 YD <sup>3</sup> (16.8 M <sup>3</sup> )		24 YD <sup>3</sup> (18.4 M <sup>3</sup> )		26 YD <sup>3</sup> (19.9 M <sup>3</sup> )		27 YD <sup>3</sup> (20.6 M <sup>3</sup> )		28 YD <sup>3</sup> (21.4 M <sup>3</sup> )		31 YD <sup>3</sup> (23.7 M <sup>3</sup> )	
(A) Overall Length, Tailgate Closed	235 in	5969 mm	255 in	6477 mm	275 in	6985 mm	289 in	7341 mm	295 in	7493 mm	309 in	7849 mm
(B) Overall Length, Tailgate Open	307 in	7798 mm	307 in	7798 mm	347 in	8814 mm	361 in	9169 mm	347 in	8814 mm	361 in	9169 mm
(C) Height: Tailgate Closed	101 in	2553 mm	101 in	2553 mm	101 in	2553 mm	101 in	2553 mm	101 in	2553 mm	101 in	2553 mm
(D) Height: Tailgate Open	145 in	3683 mm	163 in	4128 mm	145 in	3683 mm	145 in	3683 mm	163 in	4128 mm	163 in	4128 mm
(E) Max Height When Dumping	124 in	3150 mm	124 in	3150 mm	124 in	3150 mm	124 in	3150 mm	124 in	3150 mm	124 in	3150 mm
(F) Overall Width: Arm Out, Grbr Closed	209 in	5309 mm	209 in	5309 mm	209 in	5309 mm	209 in	5309 mm	209 in	5309 mm	209 in	5309 mm
(G) Overall Width: Arm In, Grbr Closed	126 in	3200 mm	126 in	3200 mm	126 in	3200 mm	126 in	3200 mm	126 in	3200 mm	126 in	3200 mm
(H) Overall Width: Arm In, Grbr Open	102 in	2591 mm	102 in	2591 mm	102 in	2591 mm	102 in	2591 mm	102 in	2591 mm	102 in	2591 mm
Grabber Height From Ground**	13 in	330 mm	13 in	330 mm	13 in	330 mm	13 in	330 mm	13 in	330 mm	13 in	330 mm

\*\*Dimension based on 40-inch chassis frame rail height. Actual dimension will vary depending on chassis measurement.

Note: Dimensions will change with roof/tailgate-mounted CNG options.



We offer a complete line of aftermarket parts and services to fit all makes and models.

## Ten-8 Industrial

Ten8Industrial.com | 877.989.7660

