



EXTRA COMPACTION REAR LOADER



Powerful rear loader with more capacity and more compaction to take on the toughest routes.

- Increased compaction force that can handle up to 1,200 pounds of refuse per cubic yard.
- Larger tailgate and hopper allow for more volume from residential to heavy commercial routes.
- Fast pack cycle time and pack-on-the-go hydraulics keep the hopper clear and help operators save time, especially on routes crowded with stops.
- Tough abrasion resistant steel used in the rear loader's highest wear areas, featuring 1/4" AR200 on the hopper floor and AR450 used in the body sidewalls.
- Like all McNeilus rear loaders, the Extra Compaction commands a top resale value of any similar truck on the market.
- Optional McNeilus® Excalibre™ cylinders feature a hardened tool steel scraper that drastically reduces hydraulic contamination.
- XXC package available for even more demanding routes that includes a thicker body floor, reinforced load edge, splash guard and extended tailgate seal.

PERFORMANCE SPECIFICATIONS (in seconds)*

WORKING RPM @ IDLE

Dump Cycle	25-27		
Sweep Extend	7		
Sweep Retract	4		
Slide Extend	5		
Slide Retract	11		
Tailgate Open	30		
Tailgate Closed	18		
Compaction = 1,200 lb/yd			
Quick Change UHMW Polyethylene Slide Shoes			
	25YD ³	28YD ³	32YD ³
Ejector Extend	20	27	33
Ejector Retract	28	30	40

*Cycle times may vary slightly

STANDARD BODY SPECIFICATIONS

Body Floor	3/16 in. AR200 5/16 in. AR200 (XXC)
Side Walls, Front Section	10-gauge AR200
Side Walls, Rear Section	1/8 in. AR450
Roof	10-gauge AR200

HOPPER SPECIFICATIONS

Hopper Capacity	3.5 cu yd
Hopper Floor	1/4 in. AR200
Hopper Sides	Top: 3/16 in. grade 50 high-strength steel, Bottom: 1/4 in. AR200
Hopper Liner	1/4 in. AR200

PACKER/EJECTOR SPECIFICATIONS

Slide Face Plate	3/16 in. grade 50 high-strength steel
Sweep Face Plate	1/4 in. AR200
Packer Edge Strip	1/4 in. grade 50 high-strength steel

TAILGATE SPECIFICATIONS

Tailgate Walls	3/16 in. AR200
Wear Strips	1/2 in. x 3 in. 1044 steel
Tailgate Seal Height	50 in

OPERATIONS

Mechanical controls with integrated control panel

HYDRAULICS

Pump	Single gear or vane with pack-on-the-go flow control system
Control Valves	Primary; Parker VA35 with Smart-Pak®
Oil Reservoir	20 yd ³ : 40 gallon 25-32 yd ³ : 50 gallon
Filter	Parker 40 CN, 100 mesh suction strainer

CYLINDERS

Ejector Cylinder	25YD³ : 7-1/2 in. bore x 7 in. rod x 119-1/2 in. stroke (4-stage) 28YD³ : 7-1/2 in. bore x 7 in. rod x 138 in. stroke (4-stage) 32YD³ : 8-3/4 in. bore x 8-1/4 in. rod x 163 in. stroke (5-stage)
Slide Cylinder	5-1/2 in. bore x 4-1/2 in. rod x 39 in. stroke
Sweep Cylinders	5 in. bore x 4 in. rod
Tailgate Cylinder	3-1/2 in. bore x 3 in. rod x 42 in. stroke

PAINTING

Packer and components steel shot blasted prior to priming with high solids epoxy primer
Finish: PPG high-performance, high solids acrylic urethane topcoat

POPULAR OPTIONS

Spool Winch or Reaving Cylinder
Guides and Latches
Container Lift Bar

McNEILUS WARRANTIES

Contact your McNeilus representative on warranty details.
For more information, go to www.McNeilusGarbageTrucks.com

EXTRA COMPACTION REAR LOADER

- McNeilus CNG Systems and Service offers compressed natural gas systems in a variety of configurations and capacities for the Extra Compaction Rear Loader.
- McNeilus partners with top equipment dealers across North America to provide best-in-class support and access to service and parts close to home.
- Proudly made in the USA.

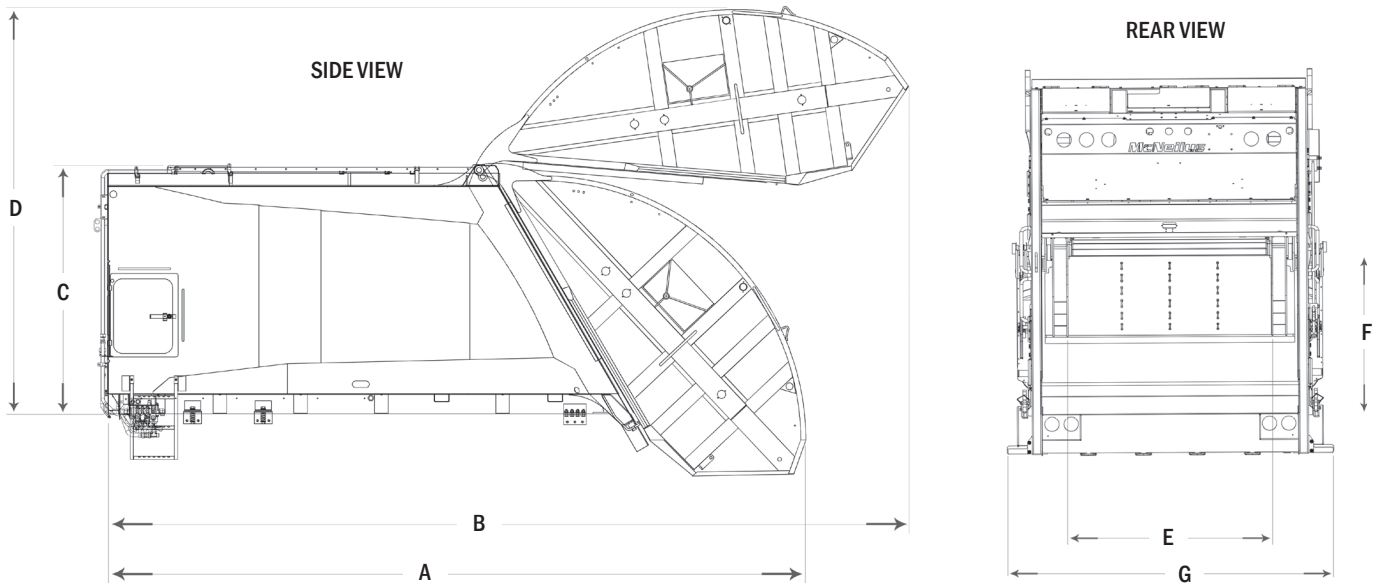

DESCRIPTION	DIMENSIONS					
	25 YD ³ (19.1 M ³)		28 YD ³ (21.4 M ³)		32 YD ³ (24.5 M ³)	
(A) Overall Length, Tailgate Closed	285 in.	7239 mm	304 in.	7722 mm	329 in.	8357 mm
(B) Overall Length, Tailgate Raised	314 in.	7976 mm	333 in.	8458 mm	358 in.	9093 mm
(C) Overall Height, Tailgate Closed**	99 in.	2515 mm	99 in.	2515 mm	99 in.	2515 mm
(D) Overall Height, Tailgate Raised**	170 in.	4318 mm	170 in.	4318 mm	170 in.	4318 mm
(E) Inside Hopper Width	80 in.	2032 mm	80 in.	2032 mm	80 in.	2032 mm
(F) Hopper Opening Height	58 in.	1473 mm	58 in.	1473 mm	58 in.	1473 mm
(G) Overall Width w/Steps	102 in.	2591 mm	102 in.	2591 mm	102 in.	2591 mm
Overall Width w/o Steps	96 in.	2438 mm	96 in.	2438 mm	96 in.	2438 mm

Note: Dimensions will change with roof/tailgate-mounted CNG options.

**Dimension with no winch. Adding a spool winch or reeving cylinder winch will increase height dimension to between 100-108 inches depending on the option chosen.



We offer a complete line of aftermarket parts and services to fit all makes and models.

Ten-8 Industrial

Ten8Industrial.com | 877.989.7660

