

McNeilus

ZERO RADIUS™ SIDE LOADER

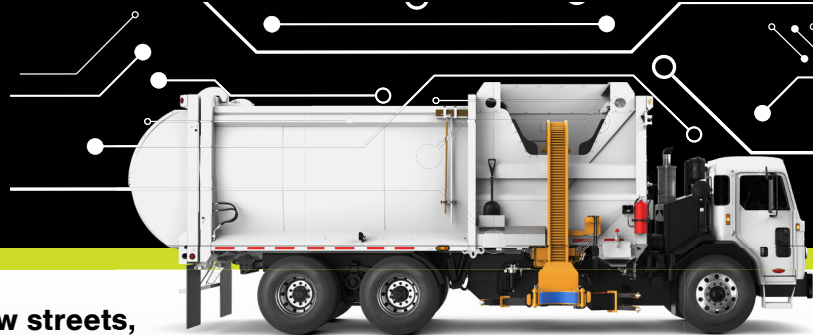

The ultimate in accessibility. Navigate narrow streets, tight alleyways and low clearance obstacles with ease.

- Fast pack cycle and industry leading hopper capacity.
- Load-sense hydraulics offer fuel cost savings, and electronic proportional controls offer smooth operate-at-idle capability.
- Arm's grabber assembly picks up cans from 30 to 110 gallons, plus an optional 12-foot reach makes it easy to navigate route obstacles.
- Full-eject body helps manage chassis wear and simplifies operations.
- Excalibre™ cylinders feature a tool steel shaver, field-proven seals and nitrided rods that drastically reduce hydraulic contamination.
- McNeilus CODE™ system provides simplified CAN-based controls with superior diagnostics and troubleshooting at your fingertips.

PERFORMANCE SPECIFICATIONS (in seconds)*

WORKING RPM @ IDLE

Arm Out	2-1/2 (6 ft only, not 12 ft arm)
Arm In	2-1/2 (6 ft only, not 12 ft arm)
Arm Up	3
Arm Down	3
Grabber Open	1-1/2
Grabber Closed	1-1/2
Pack Cycle	16 (+/- 10%)
Ejector Extend (to end of body)	27
Ejector Retract (to home position)	13
Top Door Up	1-1/2
Top Door Down	1-1/2
Tailgate Open	16
Tailgate Closed	18

*Cycle times may vary slightly

ARM ASSEMBLY

Arm Construction Tube	Grade 500B tube
Arm Style	Zero Radius (ZR)—ideal for demanding residential routes riddled with tight spaces and tough obstacles

Arm Lifting Capacity = 550 lb

Arm Reach = 6 ft (standard), 12 ft (optional)

HOPPER SPECIFICATIONS

Hopper Capacity (w/top door down)	4.8 useable cubic yards
Hopper Walls	3/16 in. AR450
Hopper Floor	1/4 in. AR450

PACKER/EJECTOR SPECIFICATIONS

Lower Packing Face	1/4 in. AR200
Packing Panel Follower	10-gauge grade 50 high-strength steel
Track and Wear Strips	Chromium carbide X-Wear

BODY SPECIFICATIONS

(Standard -more options available)*

*Body Floor	3/16 in. AR200
*Body Walls	AR450 and AR200

TAILGATE SPECIFICATIONS

*Tailgate Side Walls	1/8 in. AR200
*Tailgate Rear Wall	1/8 in. AR500

Seven-Point Automatic Locking Tailgate

OPERATIONS

McNeilus CODE™ simplified CAN-based controls offer reliable technology and features (vehicle status messages, pre-trip reminders and much more!)

Electronic proportional controls

HYDRAULICS

Pump	Piston type: load sense, PTO-mounted
Control Valves	Proportional electric/hydraulic
Oil Reservoir Capacity	50 gallon
Return Filter	5 micron-in tank
Suction Strainer	40 mesh stainless steel

CYLINDERS

Ejector Cylinder	Multistage Excalibre™ nitrided rods
------------------	-------------------------------------

PAINTING

Packer and components steel shot blasted, then primed and painted separately to provide complete top coat coverage to all areas

Finish: PPG high-performance, high solids acrylic urethane topcoat

McNEILUS WARRANTIES

Contact your McNeilus representative on warranty details.

For more information, go to www.McNeilusGarbageTrucks.com

ZERO RADIUS™ SIDE LOADER

- High quality abrasion-resistant steel in all high-wear areas for outstanding strength and durability.
- McNeilus partners with top equipment dealers across North America to provide best-in-class support and access to service and parts close to home.
- Proudly made in the USA.
- McNeilus CNG Systems and Service offers compressed natural gas systems in a variety of configurations and capacities for the Zero Radius Side Loader.

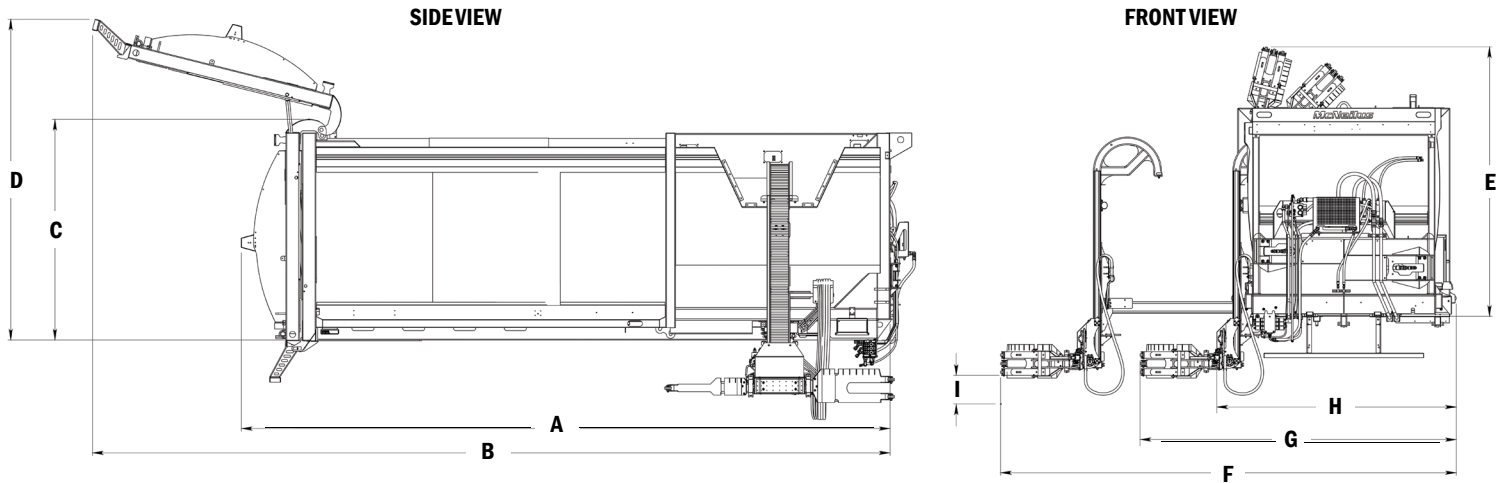

DIMENSIONS

DESCRIPTION	22 YD ³ (16.8 M ³)		24 YD ³ (18.4 M ³)		26 YD ³ (19.9 M ³)		27 YD ³ (20.6 M ³)		28 YD ³ (21.4 M ³)		31 YD ³ (23.7 M ³)	
(A) Body Length: Tailgate Closed	240 in.	6096 mm	260 in.	6604 mm	280 in.	7112 mm	294 in.	7468 mm	300 in.	7620 mm	314 in.	7976 mm
(B) Body Length: Tailgate Open	307 in.	7798 mm	307 in.	7798 mm	347 in.	8814 mm	361 in.	9169 mm	347 in.	8814 mm	361 in.	9169 mm
(C) Height: Tailgate Closed	101 in.	2553 mm	101 in.	2553 mm	101 in.	2553 mm	101 in.	2553 mm	101 in.	2553 mm	101 in.	2553 mm
(D) Height: Tailgate Open	145 in.	3683 mm	163 in.	4128 mm	145 in.	3683 mm	145 in.	3683 mm	163 in.	4128 mm	163 in.	4128 mm
(E) Max Height When Dumping	122 in.	3099 mm	122 in.	3099 mm	122 in.	3099 mm	122 in.	3099 mm	122 in.	3099 mm	122 in.	3099 mm
(F) Body Width: Arm Out, Grabber Closed 6 ft Reach (12 ft Reach)	206 in. (269 in.)	5232 mm (6833 mm)	206 in. (269 in.)	5232 mm (6833 mm)	206 in. (269 in.)	5232 mm (6833 mm)	206 in. (269 in.)	5232 mm (6833 mm)	206 in. (269 in.)	5232 mm (6833 mm)	206 in. (269 in.)	5232 mm (6833 mm)
(G) Body Width: Arm In, Grabber Closed	143 in.	3620 mm	143 in.	3620 mm	143 in.	3620 mm	143 in.	3620 mm	143 in.	3620 mm	143 in.	3620 mm
(H) Body Width: Arm In, Grbr Open	115 in.	2921 mm	115 in.	2921 mm	115 in.	2921 mm	115 in.	2921 mm	115 in.	2921 mm	115 in.	2921 mm
(I) Grabber Height from Ground**	12 in.	305 mm	12 in.	305 mm	12 in.	305 mm	12 in.	305 mm	12 in.	305 mm	12 in.	305 mm

**Dimension based on 40-inch chassis frame rail height. Actual dimension will vary depending on chassis measurement.

Note: Dimensions will change with roof/tailgate mounted CNG options.



We offer a complete line of aftermarket parts and services to fit all makes and models.

Ten-8 Industrial

Ten8Industrial.com | 877.989.7660

